



MESSER 
Cutting Systems

METALMASTER Xcel PRODUCTIVE PRECISION FOR THE PROFESSIONAL PROFILER

METALMASTER Xcel

PRODUCTIVE PRECISION FOR THE PROFESSIONAL PROFILER



Bevel-R for flexible plasma contour bevel cutting



High efficiency with innovative fibre laser technology

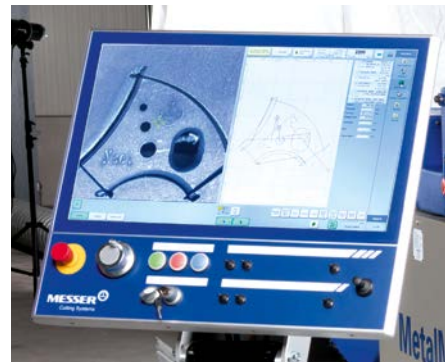

The Global Control with 24" screen gives intuitive operation to speed set-up and reduce errors



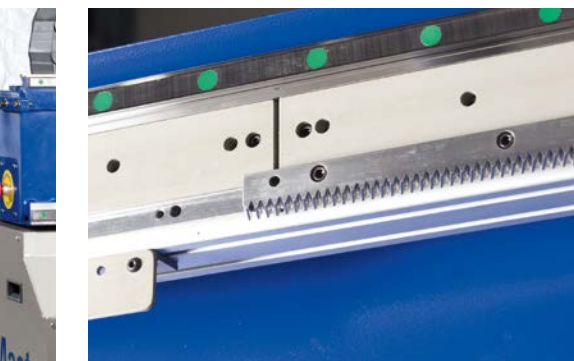

Helical drive gears with linear guides give precision and a smooth drive for top quality cuts and accuracy



METALMASTER Xcel YOUR BENEFITS:

- High positioning speed reduces time between cuts
- High cutting quality and accuracy save costs for secondary operations
- High acceleration means accurate, good quality cuts even on small parts and cut-outs
- Smooth guidance through helical gears for cleaner, faster cutting
- Multiple processes mean you can select the optimum cutting process not only for each part but also for each contour within a part
- Integrated self-cleaning table removes slag and small parts automatically, avoiding loss of time for table cleaning
- Unitised design means no rails in the way to hinder loading and unloading – saves handling time
- Ideal for integration into an automatic plate handling system
- Laser pointer and plate alignment compensation speeds plate changeover
- Global Control with 24" screen and integrated database for fast set-up and reduced errors
- Windows based PC control gives easy integration into your factory LAN system
- Remote service gives fast diagnosis and support in the unlikely event of a fault
- Sure stop collision sensor with easy and accurate reset avoids damage to torch and down time
- High speed lifter reduces time between cuts and reacts accurately to uneven plates
- Bevel heads for plasma and laser cutting available for increased flexibility
- Suitable for cutting all common metals (Mild Steel, Stainless Steel, Aluminium etc.)
- Optional Video camera for ease of operation
- Available for plate widths up to 3 m and lengths up to 15 m so can be tailored to meet your needs
- Optional tools (e.g. marking heads) available for increased versatility

METALMASTER Xcel

Technical Data (all dimensions in mm)

MetalMaster Xcel	4020	4025	6020	6025	6030	8025	8030	Table height
A Working Length	4000	4000	6000	6000	6000	8000	8000	920
B Working Width	2000	2500	2000	2500	3000	2500	3000	920
C Overall length	8650	8650	10650	10650	10650	12650	12650	920
D Overall Width	4525	5025	4525	5025	5525	5025	5525	920

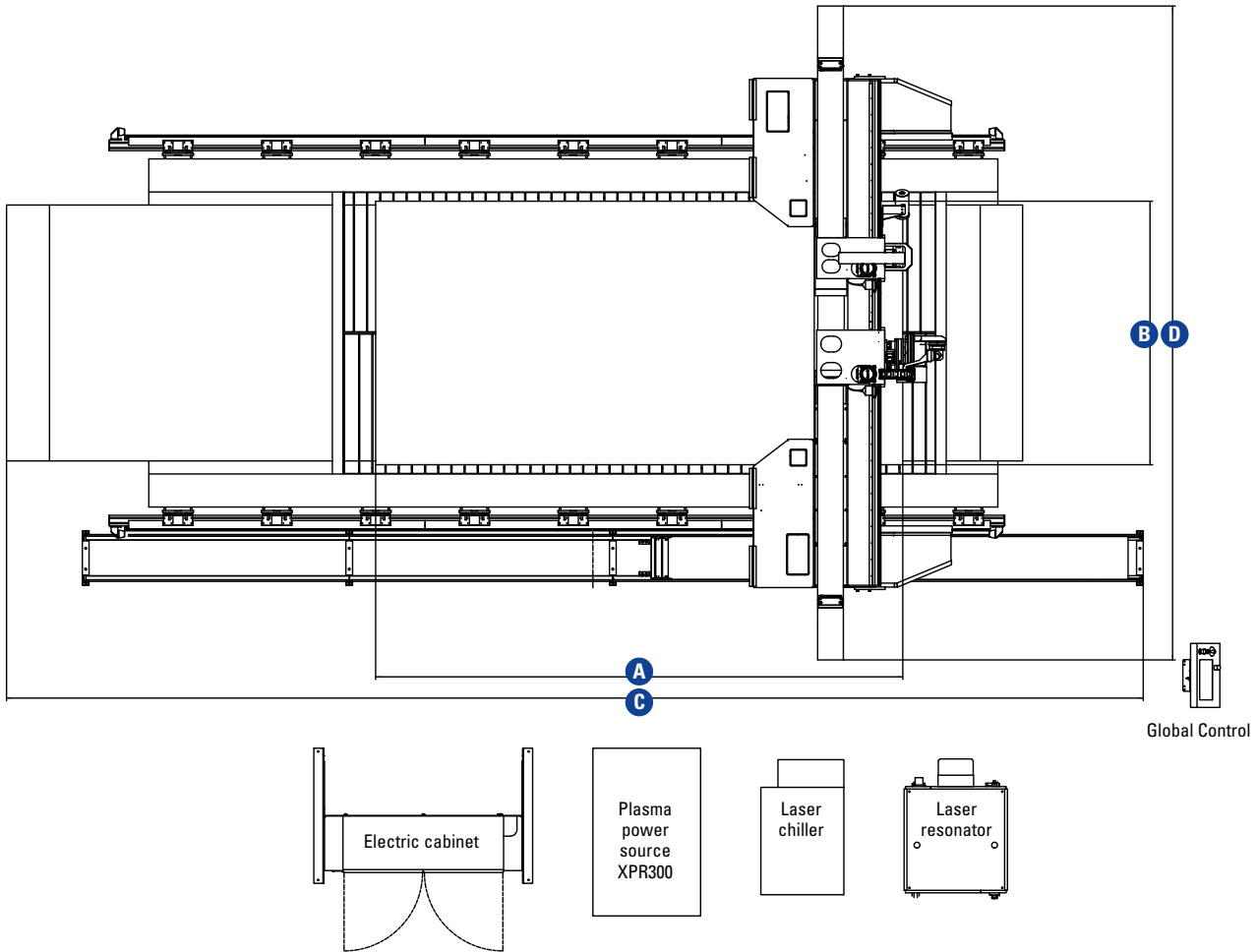

Messer Cutting Systems GmbH
 Otto-Hahn-Strasse 2-4
 64823 Groß-Umstadt
 Germany
 Phone +49 (0) 6078 787-0
 Fax +49 (0) 6078 787-150
 info@messer-cutting.com
 www.messer-cs.de